

Storz[®] Performance Inc.



Storz/Ceriani[®] Forks

**PERFORMANCE
ACCESSORIES
CATALOG**



CUSTOMER NUMBER

So here we go again, we're starting our 37th year in business!

I love the motorcycle business and I feel privileged to have worked exclusively in the industry for nearly 50 years. In my experience, motorcyclists in general are a very special group of people and we enjoy working hard to meet your needs.

Be assured that we will continue to provide top quality parts at a fair price with prompt delivery and excellent customer service. As always, your suggestions are most welcome.

We wish all of you another happy and safe riding year!



Steve Stoy

Take a moment if you like to check out the YouTube video of my induction to the 2016 Trailblazers Hall of Fame. It was a career highlight that I'm very proud of.



<https://www.youtube.com/watch?v=b80eiI8Eo98>

Follow Us on



Find Us on



Instagram

NEW STORZ SP1200RR CAFE RACER CONVERSIONS



Storz Performance has developed a new line of Café Racer style accessories for use on 2004 to current model Harley-Davidson Sportsters. A new show bike, the Storz SP1200RR, has been constructed to serve as a rolling display case for these items. A hand formed aluminum gas tank and road race style fiberglass tail section with custom Saddlemen seat pads creates the basis for the look. Specially modified clip-on handlebars by Driven are mounted to the Storz/ Ceriani 55mm Inverted fork tubes above the top triple clamp. Ohlins rear shocks with adjustments for compression & rebound damping, spring preload, and overall length, complete the suspension package.

The donor bike for this project was a low mileage 2007 model 883 Sportster, but installation of a Wiseco piston kit increased the displacement to the 1200cc level. A BUB / Storz 2:2 high pipe exhaust and a Performance Machine air cleaner handle the breathing chores on this fuel injected bike.

The bike rolls on 18" wheels, front and rear, with Metzeler tires, Galfer Floating Wave Brake Rotors, and Performance Machine brake calipers. A Storz billet rear set footpeg kit, Barnett custom cables, PM hand controls, and a Storz/Ceriani Steering Damper keep things under control. Pearlescent paintwork done by Vintage Restorations, Oxnard, CA.



STORZ SP1200RR CAFÉ RACER PARTS LIST

P/N	Description
AT-1200RR	Alloy Gas Tank, 2004-06
AT-1207RR	Alloy Gas Tank, 2007 +
FGL-300	Fiberglass Tail Section w/ Seat Pads
ML-351-04	Tail Lamp and Seat Mount Kit
IF-255	Plastic Inner Fender
HD144	Onlins Shock Set, 14 1/8"
HD255B.3334-DSB	Storz/Ceriani 55mm Inv. Fork Legs
HD255.03-PB	Mid Triple Tress, polished black
HLB4354	Headlamp Adaptor Bracket
DCLO-55BK1	Billet Clip-on Bars. 1" diameter
19248	Wheel Spacer Kit
08837	Front Brake Line Kit



P/N	Description
FW1835-B	Front Wheel, 18x 3.5" polished black
RW1855-B	Rear Wheel, 18x 5.5" polished black
ME880F	Metzeler Front Tire 130/70-18 (ref.only)
ME880R	Metzeler Rear Tire 180/55-18 (ref.only)
1200WT	Chain Drive Kit (for 520 size chain)
GF680F	Galfer Wave Brake Disc 11.5 dia. (x3)
HD083-04	Billet Rearset Footpeg Kit
08845	Rear Brake Line Kit
HD883-R	Steering Damper Kit
0053-2919-BM	PM Brake Caliper 137x4B LT Front
0053-2920-BM	PM Brake Caliper 137x4B RT Front



P/N	Description
1293-0052-B	PM Rear Brake Disc Kit
0063-2023-B	PM Billet Handgrip Set
0063-2002-B	PM Throttle Housing
0062-2035-B	PM Switch Assembly, 3 Button Lt
0062-2032-B	PM Switch Assebley, 3 Button RT
0062-2910-BM	PM Handmaster Cylinder 11/16"
0062-2030-B	PM Clutch Perch
	PM Spacer for Clutch Perch
0062-2612-B	PM Brake Light Swith Assembly
0206-2008-B	PM Air Cleaner Assebley, black
Please call for estimates on complete bike builds.	

STORZ UPGRADES FOR THE H-D XR1200



BILLET SHIFTER KIT FOR XR1200

CNC machined from 6061-T6 aircraft aluminum billet, our shifter kit replaces the clunky stock unit and does away with the long shifter rod and levers of the standard shifter. The result is a lightweight compact shifter mechanism with much more precise shifting and better looks. One of our most popular items for the H-DXR1200. **HD083.55**



BILLET ALUMINUM FOOTPEGS

These are the same knurled billet footpegs we use in our rearset kits for Sportsters. They will also fit in the stock H-D XR1200 footpeg clevis with original return springs. Lighter and better looking, they also fit the passenger footrest mounts.

HD083.03 (order X2 for rider, X4 for rider and passenger)



LED TAIL LAMP KIT FOR XR1200

Intended as a replacement for the bulky stock non-led tail light, this easy to install bolt-on kit features a compact LED tail lamp with clear lens, laminated stainless steel license plate holder, aluminum mounting bracket, installation instructions, and all necessary hardware. It fits all models of XR1200 from 2008 to present. An optional LED turn signal kit with black anodized billet aluminum machined signals is also available.

TL-400 LED Tail Lamp and License Plate Holder Kit
TL-401 Optional LED Turn Signal Kit



SOLO SEAT TAIL SECTION FOR H-D XR1200 2008 AND UP

This is a lightweight racing type fiberglass tail section that replaces the stock tail section and eliminates the stock passenger seat pad. It is supplied unpainted in white gelcoat finish and is compatible with the stock XR1200 seat pad, or it will also accept the new Saddlemen seat pad. It bolts on in place of the stock tail section using existing hardware.

FGL-400



SADDLEMEN SEAT PAD

This is a replacement seat for the stock H-D XR1200 seat pad. It is slightly thicker than the stock seat pad, but more importantly it features an improved shape along with a gel insert for maximum comfort. It is intended to fit the stock seat section or the racing style solo seat section (FGL-400) and mounts using the stock hardware.

FGL-1200.01



STORZ/CERIANI STEERING DAMPER KIT FOR 2008 AND UP H-D XR1200

A 16 position precision, racing quality steering damper that mounts to the frame and fork with billet aluminum mounting brackets. Steering dampers dampen oscillations in the front fork assembly (also known as "head shake"). The amount of damping force can be adjusted by turning the knob on the end of the damper shaft.

HD1200R



BRAKE TECH FULL FLOATING FRONT DISC KITS FOR H-D XR1200 2008 AND UP

These 320mm diameter full floating front rotors feature a unique aluminum center section design to control the radial and axial float of the outer discs, which are available in stainless steel or ductile iron. The kit includes CNC machined billet aluminum caliper adaptor brackets so that they can be used with the stock OEM brake calipers on the stock front fork. Even with the increased diameter, they are still lighter than the stock OEM front brake discs.

BT320SS (stainless outer disc)

BT3220DI (ductile iron outer disc)

YSS PERFORMANCE SHOCKS FOR H-D XR1200 AND SPORTSTER

Unlike the stock shocks which have no adjustment for damping force, these racing quality YSS shocks have individual adjustments for compression and rebound damping as well as a piggyback style reservoir with bladder to separate the shock oil and gas. They feature massive 36mm pistons and 16mm shafts for precision operation and are also adjustable for overall length and spring preload. A choice of spring rates is also available. Available lengths are 330mm (12.99"), 340mm (13.38"), 350mm (13.78"). Longer lengths also available on special order basis.

RG366



RG362 shocks are very similar to the RG366 model shown above, the main difference being 12mm diameter shafts vs. 16mm. They have separate adjustments for compression and rebound damping as well as spring preload and overall length. They are available in the same lengths as the RG366 shown above.

RZ366 are also similar to the RG366 shocks, but without the piggyback reservoir. They are adjustable for spring preload and rebound damping as well as overall length. They are available in the same lengths as the RG366 shocks.

NOTE: These are a good choice for someone using our dirt track style seat conversion kit on a Sportster because they don't interfere with the mounting points on the side of the seat section.

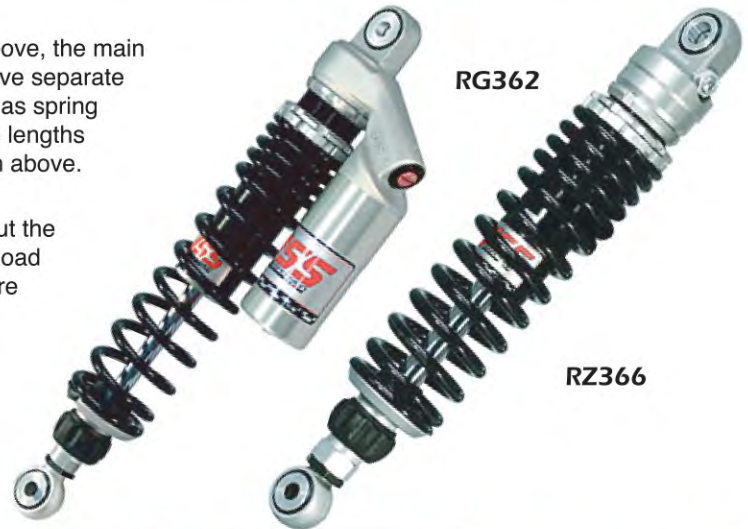

BRAIDED STEEL FRONT AND REAR BRAKE HOSE KITS FOR H-D XR1200 2008-10

These kits replace the original stock rubber front brake hoses that come on the XR1200 with race quality dash 3 size braided steel brake lines that are covered with a black vinyl coating to prevent scratches to surrounding components. The kit includes a billet brake line junction block that mounts below the lower triple tree and facilitates a clean simple routing for the brake lines. Mounting hardware is included.

08838 Front Brake Hose Kit

08839 Rear Brake Hose Kit (Not Shown)





Wire Spoke Wheel Kits for Sportster, XR1200, Dyna and FXR

Complete wheels feature Made in USA Billet aluminum hubs, Excel clear finish rims, polished stainless steel spokes & nipples. Our Sportster based Storz SP1200 show bike runs 18 x 3.5 front and 18 x 5.5 rear rim sizes*. The stock H-D XR1200 runs an 18 x 3.5 front and a 17 x 5.5 rear. Optional front wheel size is 17 x 3.5

FW1735 Front Wheel 17 x 3.5 **RW1755** Rear Wheel 17 x 5.5
FW1835 Front Wheel 18 x 3.5 **RW1855** Rear Wheel 18 x 5.5

NOTE: For optional polish and color anodized finish on rims, add -G for Gold or -B for Black to the part number above.

HD55-305 Front Disc spacer for H-D XR1200

19350 Spacer kit for wire spoke wheel in XR1200 front fork

HD55-750 Rear pulley spacer for H-D XR1200

19352 Spacer kit for wire spoke wheel in XR1200 swingarm

Rim & Spoke Kits and Billet Hubs are also available individually. Billet hubs are supplied with bearings and inner spacer. Specify bearing size 3/4", 1" or 25mm.

FH101-S Billet Hub Front or **FH 101-D** Dual

RH102- Billet Hub Rear

BRS350 18 x 3.5 front rim and spoke kit, clear finish Excel rim with polished stainless spokes & nipples.

BRS550 18 x 5.5 rear rim and spoke kit, clear finish Excel rim with polished stainless spokes and nipples.



*2004-2010 Sportsters require chain drive kit, p/n 1200WT to allow use of 180mm wide rear tire. NOTE: Stock Sportster rear fender will not fit with 180mm rear tire. You must use Storz dirt track style tail section, FGL-250 or FGL-255.



10-INCH REAR DISC KIT FOR SPORTSTERS

Designed to replace the stock Sportster 11.5" rear disc and caliper, this floating rear disc kit features an aluminum caliper hanger which will accept a Grimeca 1050/55 or PM 125 x 4R brake caliper. The 4130 chrome moly torque arm transfers braking forces to the main frame which reduces wheel hop under hard braking. Kit includes disc, caliper hanger, torque arm, and mounting lug.



NOTE: 1984-2003 kits use a round stainless steel disc (fixed mounting not floating). 2004 and later kits use floating Storz/Galfer wave disc.

- RD883** 10" round disc kit without caliper (1984-2003)
- RD1200** 10" wave disc kit without caliper (2004-Present)
- RD1201** 10" wave disc kit without caliper (2005-Present)



STORZ 2000 AND UP BRAKE CALIPER ADAPTER KITS

This kit allows owners of pre-2000 model Harley-Davidsons with 39mm or 41mm forks to retrofit the new 2000 and up H-D 4 piston disc brake caliper to their existing stock fork, wheel, and disc.

NOTE: Will not fit narrow hub FXR/XL with wire spoke wheel.

The adapter bracket itself is a CNC machined part and is available in satin or chrome finish. The kit is supplied with chrome plated mounting hardware and complete instructions.

- HD55A.70S** Satin Finish Smooth
- HD55A.70C** Chrome Finish Smooth

RIMS AND SPOKES

Our 883 project bike rolls on flat track style 18" Sun rims laced to the stock Harley hubs with stainless spokes. Rim sizes are 2.15 x 18" front; 2.75 x 18" rear. Tire sizes (for reference only - not available from us) are Dunlop K591 110/90 V18 front, 130/80 V18 rear.

For 86-03 Sportsters

- BRS215** Front rim and spokes
- BRS275** Rear rim and spokes

The new 1200 features much wider 18" rims laced to stock Harley hubs. Sizes are 18 x 3.5 front, 18 x 5.5 rear. Tire sizes are (for reference only - not available from us) Metzeler 130/70-18 front, 180/55-18 rear, 2004-08 only.

For 04-10 Sportsters* (Except XR1200)

- BRS350** Front rim and spokes
- BRS550** Rear rim and spokes

* Note: 5.5 rim

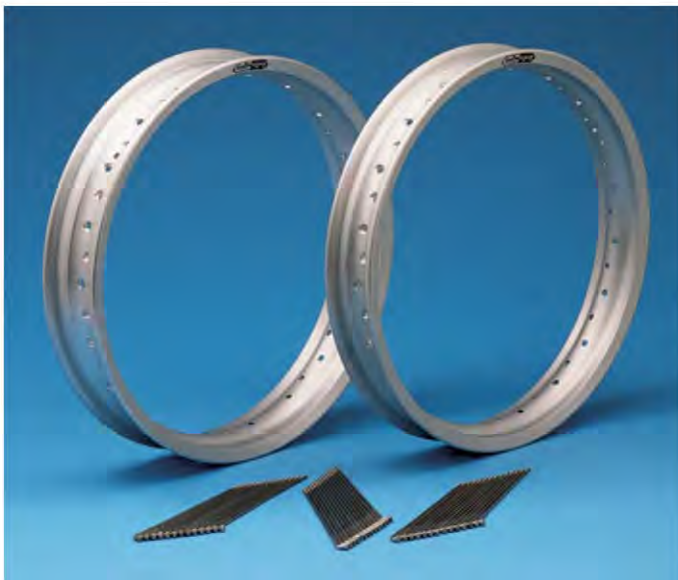

STORZ / CERIANI 55mm CHROME INVERTED FORKS

This fork is the first in a series of popular Inverted fork designs from Steve Storz & Enrico Ceriani which features flat sided lower legs with our patented concealed axle system. Intended for use on stock and custom framed Harley-Davidsons, it features precision cartridge damping, progressively wound fork springs, and a built-in lowering kit which allows the fork leg to be shortened by 1" without complete disassembly of the fork. The fork can be used with stock or custom wheels and will accept stock H-D fenders (with adaptor bracket) or custom fenders can be bolted directly to the lower leg.

This original style fork has been updated with the following improvements:

We now offer our one-piece billet lower legs with brake mounts for the 2000 and later style H-D or aftermarket direct bolt-on brake calipers. The lower legs have been modified to allow the axle to thread into the left leg which completely conceals the axle, eliminating the need for a separate axle nut, washer, and axle cover.

See page 13 for part numbers and ordering information.

Congratulations to Rob Schopf and the crew at Hal's Harley-Davidson in New Berlin, Wisconsin for building the winning machine in the 124 VFI Ultimate Challenge competition. This beautiful machine is equipped with a Storz/Ceriani 55mm Inverted chrome fork.

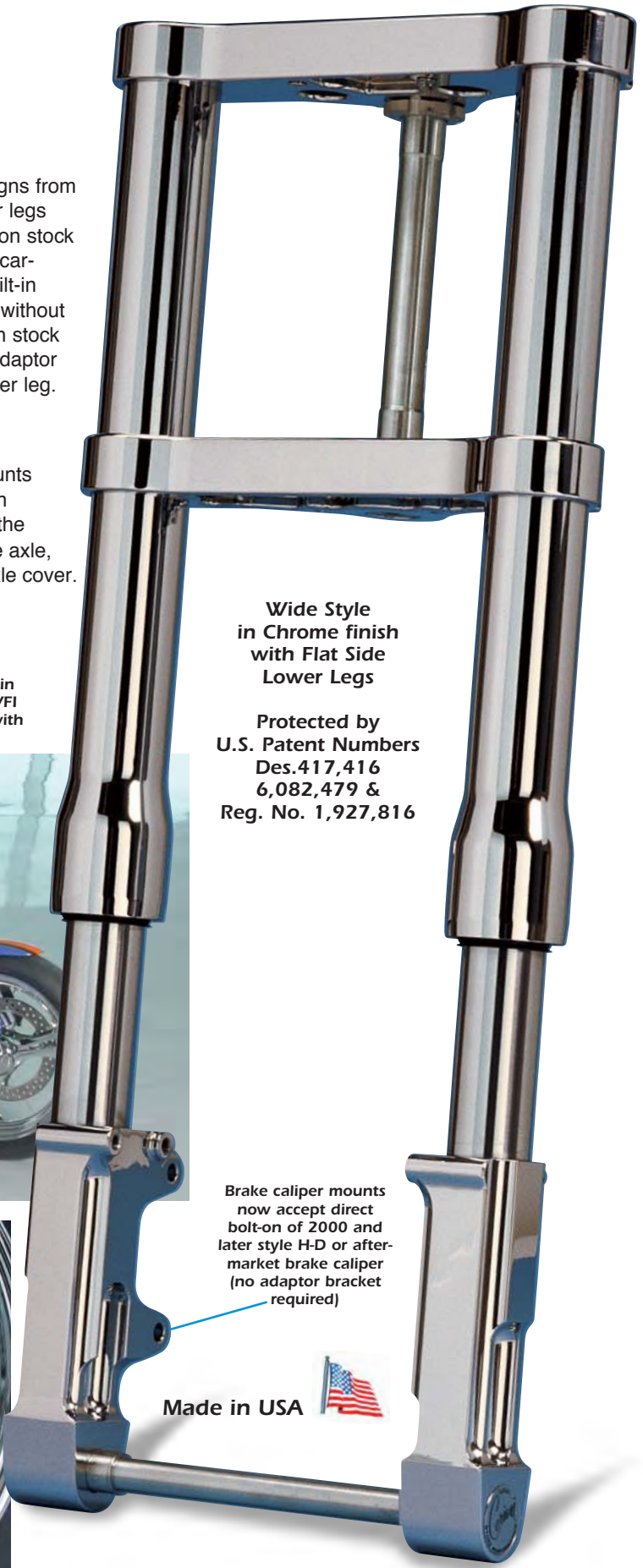

Wide Style
in Chrome finish
with Flat Side
Lower Legs

Protected by
U.S. Patent Numbers
Des.417,416
6,082,479 &
Reg. No. 1,927,816

Brake caliper mounts
now accept direct
bolt-on of 2000 and
later style H-D or after-
market brake caliper
(no adaptor bracket
required)

Made in USA



55mm "BLACKOUT" INVERTED FORKS

The forks shown here share the technical features with our chrome inverted forks (page 8) including cartridge damping, progressively wound fork springs, and built-in lowering kit, but they have a black polished anodized finish instead of chrome. They are also available in a less expensive black satin finish. The brake attachment lugs are designed to accept the H-D 2000 and later style 4 piston caliper or aftermarket equivalent.

If you have technical questions or you need help in ordering just give us a call at 805-641-9540 and we will be happy to help you place your order.

ORDERING INFORMATION

The fork legs and triple trees each have their own part numbers so you can mix and match any finish and style of these items. Triple Trees are available in Mid and Wide styles and are listed separately on Page 10. Axles and T-stems are included with the triple trees. Fork stops, wheel spacers, and fender brackets must be ordered separately.

Fork Leg Part Numbers

HD255B.3132 31/32" length (standard) for 2000 & up calipers
HD255B.3334 33/34" length (+2") for 2000 & up calipers

*Specify single disc (add-S) or dual disc (add-D) to part number suffix. Specify chrome finish (-C), polished black anodized finish (-PB), or satin black anodized finish (-SB)

Example: HD255A.3132DPB would be dual disc legs with polished black finish

Wide Style
Blackout in Polished
All Black Finish

Protected by
U.S. Patent Number
Des. 417,416
6,082,479 &
Reg. No. 1,927,816



Storz "Dynalite" FXDX Project Bike

Made in USA



FORK TREES FOR STORZ CERIANI INVERTED FORKS

We are now listing triple trees and fork legs separately to allow you to mix and match styles and finishes as you like. All Inverted trees now feature a smooth top surface as we use a new t-stem design which threads into the bottom side of the upper tree. Mid & Wide Style trees are available in "0" degree (parallel) only. The trees are available in three different finishes: Chrome, Polished black Anodized, Satin Black Anodized.

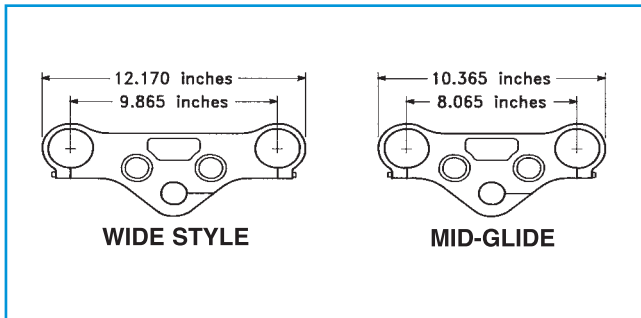

- HD255.03C** Mid Glide Chrome
- HD255.03PB** Mid Glide Polished Black Anodized
- HD255.03SB** Mid Glide Satin Black Anodized
- HD255.03WC** Wide Style Chrome (flat front)
- HD255.03WPB** Wide Style Black Polished (flat front)
- HD255.03WSB** Wide Style Satin Black Anodized (flat front)

All trees are supplied with axle & t-stem. Wheel spacers, fender brackets, and fork stops must be purchased separately.

FORK ACCESSORIES

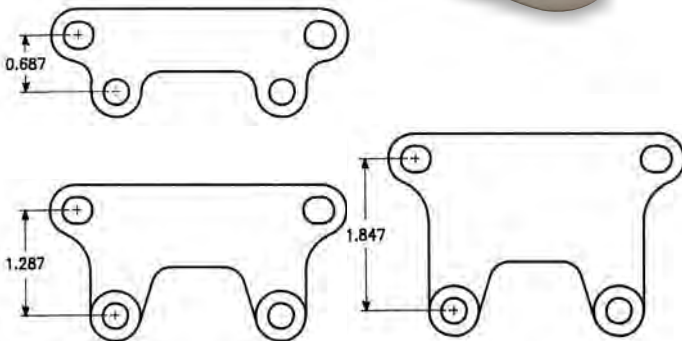
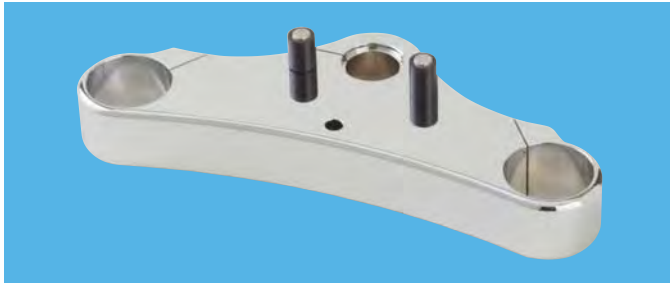
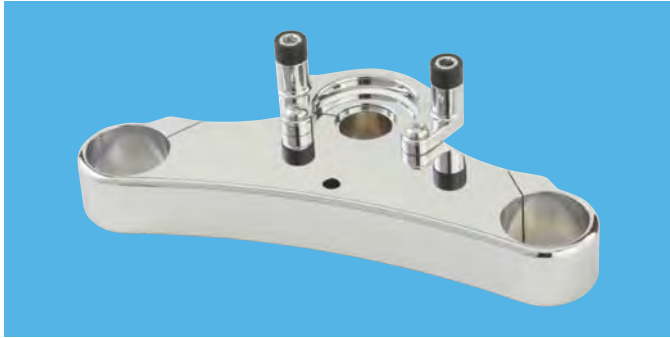

FORK STOP KITS - Bolt-on Style

For every fork order you must select a fork stop kit. There are three types, two for Softail frames, the other for DYNA/FXR/XL frames.

For H-D 84-99 Softail Frames
HD43A.02-95S Satin finish
HD43A.02-95C Chrome finish

For 2000 & up Softail Frames
HD43A.00-95S Satin finish
HD43A.00-95C Chrome finish

For DYNA, FXR, & XL
HD43A.24S Satin finish
HD43A.24C Chrome finish



INTERNAL FORK STOP KITS

For use on frames with removable bearing cup holders (e.g. Softail). Kits are available complete with bearing cup holders, bearings, races, and lockplate or lockplate only in 35 degree or 45 degree turning radius.

Complete kit with bearings, cups, races, and lockplate
IFS4955-TS4

FENDER BRACKET KITS

HD45A.60C FLSTF (Fatboy) for Wide Style
HD45A.60C-X FLSTC (Heritage) for Wide Style
HD45A.61C FXST/FXDWG for Wide Style, FXR, FXD, XL, for Mid
HD45A.62C FXR/XL for Wide Style
HD45A.63C Xtra Tall - FXST/FXDWG for Wide Style with 90/90-21" tires
HD45A.64C Duece Fender Brackets

WHEEL SPACER KITS

- | | | | |
|--------------|--|--------------|---|
| 19239 | '84-99 FXR/XL Narrow Hub or Cast Wheel in Storz Mid Fork | 19246 | 2000-06 XL Narrow Hub in Storz Wide Fork, 3/4" axle |
| 19240 | '84-99 Wide Glide Hub (Single Disc) in Storz Wide Fork | 19247 | 2005-07 FXD Narrow Hub in Storz Wide Fork, for 1" axle bearings |
| 19242 | 2000-04 Wide Glide Hub in Storz Wide Fork, 3/4" axle | 19248 | 2005-07 FXD Narrow Hub in Storz Mid Fork, for 1" axle bearings |
| 19243 | 2000-06 XI Narrow Hub or Cast Wheel in Storz Mid Fork, 3/4" axle | 19249 | 2007-08 Wide Glide Hub in Storz Wide Fork, for 25mm axle bearings |
| 19244 | 2000-06 Fatboy Wheel in Storz Wide Fork, 3/4" axle | 19250 | 2008 FXD Cast 16" Wheel in Storz Wide Fork with 25mm bearings (requires axle shoulder-150°) |
| 19245 | '84-99 FXR/XL Narrow Hub or Cast Wheel in Storz Wide Fork | 19251 | 2008 XL/FXD Narrow Hub in Storz Mid Fork with 25mm bearings |
| | | 19252 | 2008 XL/FXD Narrow Hub in Storz Wide Fork with 25mm bearings |

BRAIDED STEEL FRONT BRAKE LINE KITS

Don't settle for anything less than a custom fit front brake line kit with billet aluminum "T" block that mounts below the lower triple clamp. Kit includes size -3 AN banjo fittings, banjo bolts, washers, and braided steel hose. Only hand tools required.

08836 Single caliper front kit **08837** Dual caliper front kit



NOTE: These brake lines are not clear coated

08837

STORZ BILLET BAR MOUNTS

Our Tom Foster designed billet bar mounts are back in production again. Their clean, simple look really compliments the shape of our billet trees. Supplied in polished aluminum finish.

HD4355 Billet Bar Mounts - rigid mount
HD4355R Billet Bar Mounts - rubber mount
HD4355TS Tach Speedo Mount kit - rubber mount

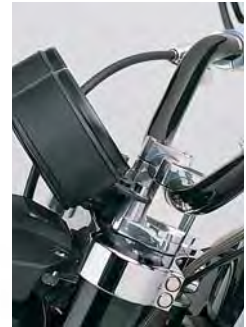

HEADLIGHT VISOR BRACKET



For use with stock FXR-FXD-XL top mount headlights **HLB4354**

BRAKE DISC SPACER KIT

These are required only if the FXR narrow hub is to be used with the Wide Style forks. Order one for each disc to be used.

HD55-116 '84-99
HD55-200 2000-up



FORK SERVICE TOOLS

Aluminum soft jaws for holding the steel fork tube safely in a vise during fork disassembly.

FT43MM 43mm diameter tubes
FT45MM 45mm diameter tubes
FT49MM 49mm diameter tubes
FT5481A1 Pin spanner for top fork cap (G.C.B., Forcelle Italia, and Storz / Ceriani Inverted forks only)
FT4354 Pin spanner for fork seal retainers (all G.C.B. and Forcelle Italia)



FT4354

FT5481A1

FORK OIL

For Storz / Ceriani forks we recommend Golden Spectro fork fluid or for slightly heavier damping action, Bel-Ray H.V.I. Suspension Fluid.

GS85/150 Golden Spectro Fork Fluid
BR-HVI-15W Bel-Ray H.V.I. Suspension Fluid

REPLACEMENT OIL SEALS

HD55.22 Oil seal for HD45 & HD55 forks
HD49.22 Oil seal for HD49 series forks

TURN SIGNAL CLAMPS

These machined billet aluminum signal clamps are for use with Storz/Ceriani 45mm and 55mm forks.

TC-550 55mm Satin finish
TC-550C 55mm Chrome finish



BRAIDED STEEL HOSE AND FITTINGS

Custom make your own hose kits for a perfect fit. Easy-to-install hose ends and fittings require only a hacksaw and open end wrenches for assembly. Widely accepted in all forms of racing as the **only** hose to use for the flexible brake and clutch lines on racing cars and motorcycles. The stiffness of the Teflon® liner, combined with the resistance of the stainless steel braided outer cover, dramatically reduces brake line expansion under pressure resulting in a more controlled brake pedal. The improved abrasion and heat resistance are secondary but nice. All of our hose fittings are supplied in -3AN size only.

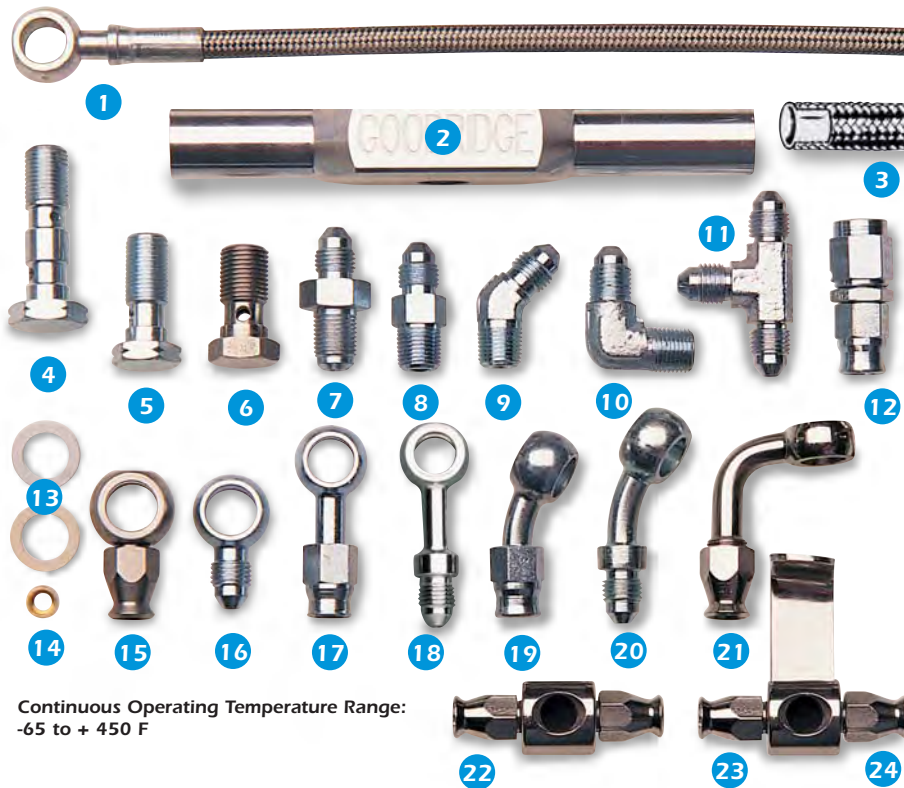

Continuous Operating Temperature Range:
-65 to + 450 F

- 1) Hose with swaged ends:
 - 0814 14" hose (center to center)
 - 0815 15" hose
 - 0816 16" hose
- 2) 8001C Billet front fork "T" Fitting Chrome
- 3) 6100 -3 Hose (per foot)
- 4) Double Banjo Bolt
 - 7519 10mm x 1.0
 - 7518 10mm x 1.25
 - 7513 3/8 - 24
 - 7303C 3/8 - 24
- 5) Single Banjo Bolt
 - 7517 10mm x 1.0
 - 7515 10mm x 1.25
 - 7503 3/8-24 (Lockheed)
 - 7503C 3/8-24 (Lockheed)
- 6) 7544 7/16-24 (for H-D)
 - 7544C 7/16-24 (for H-D)
- 7) Metric Str. to -3 fitting
 - 2032 10mm x 1.0
 - 2035 10mm x 1.25
- 8) 1603 Str. 1/8 NPT to -3 fitting
- 9) 2303 45 degree 1/8 NPT to -3 fitting
- 10) 2203 90 degree 1/8 NPT to -3 fitting
- 11) 2403 "T" for -3
- 12) 0103 Hose End Str.
 - 6001C Hose End Str.
- 13) Crush Washers
 - 3203 10mm inside diameter
 - 3204 3/8" inside diameter
 - 3205 7/16" inside diameter
- 14) 0003 Replacement Ferrule for -3 hose ends
- 15) 0903 Banjo Hose End, Str.(7/16" I.D.) for H-D
 - 0903C Banjo Hose End, Str.(7/16" I.D.) for H-D
- 16) 7634 Banjo Str. (7/16" I.D.) to -3 fitting
- 17) 0703 Banjo Hose End, (10mm I.D.)
 - 5092C Banjo Hose End, (10mm I.D.)
- 18) 9203C Str. Banjo, chrome to -3 hose fitting
- 19) 0803 Banjo Hose End, Bent 35 degrees
 - 5070C Banjo Hose End, Bent 35 degrees
- 20) 9303C Banjo, Bent 35 degrees to -3 fitting
- 21) 5099C Banjo Hose End, Bent 90 degrees
- 22) 02UN Brake Light Adapter
- 23) 04ST Rear Brake Switch, for H-D Softail
- 24) 03SP Rear Brake Switch, for H-D Sportster

INSTRUCTIONS FOR BRAIDED STEEL HOSE ASSEMBLY

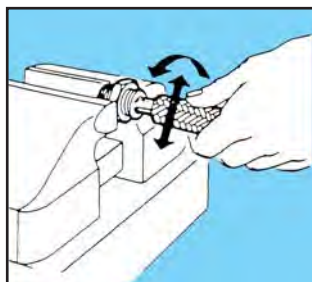

Step 1. Wrap hose with masking tape at cut-off point and cut squarely through the tape with a fine tooth hacksaw. Remove the tape and flush-trim loose wires. Remove burrs on inner bore of hose with a knife then clean hose bore. Slide the two hex fittings back to back over hose. Mount nipple hex in a vise and work hose bore over it. This sizes the tube and separates braid prior to fitting sleeve. Remove hose from nipple.

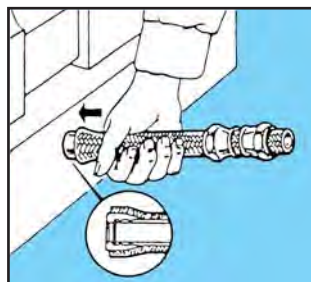

Step 2. Push the sleeve over the end of the tube and under the wire by hand. Complete positioning of the sleeve by pushing the hose end against a flat surface. Visually inspect to see that the tube butts against the inside shoulder of the sleeve. Set the sleeve barbs into the Teflon tube by pushing a round nose tapered punch into the end of the sleeve and tube.

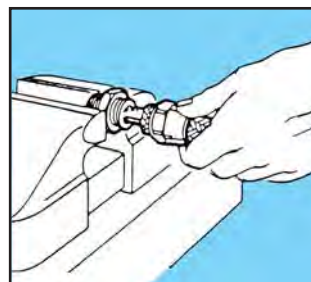

Step 3. Lubricate nipple and socket threads with anti-seize compound (e.g. Molykote Type G). Hold the nipple with hex in the vise. Push hose over nipple with twisting motion until it is seated against nipple chamfer. Push socket forward and start threading of socket onto nipple. Be careful not to cross thread.

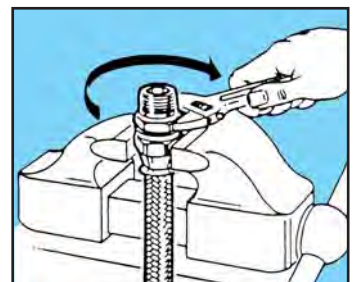

Step 4. Wrench tighten nipple hex until clearance with socket hex is 1/32" or less. Tighten further to align corners of nipple and socket hexes. **CLEAN, PROOF TEST TO TWICE OPERATING PRESSURE AND INSPECT ALL ASSEMBLIES.** To disassemble: unscrew and remove nipple; slide pocket back on hose by tapping against flat surface; remove sleeve with pliers.

SPORT PARTS FOR BUELL



STEERING DAMPER KITS FOR BUELL

These 16-position adjustable rebuildable, racing quality steering dampers bolt to the frame and fork using our 2-piece billet aluminum mounting clamps. Their function is to dampen oscillations in the front fork ("headshake") when the wheel is deflected from its normal track by road surface, tire reaction, etc. Full fork movement is retained.

- 22120 S1,S2,S3
- 22121 M2
- 22122 XB9R 2003-04
- 22123 XB9S, XB12S, XB9SX 2003-04
- 22124 XB9R, XB12R 2005-06
- 22125 XB9SX, 12S, 12X, 12Ss, Scg 2005-07

Note: Kit 22120 can also be installed on X1, but side plastic cowl below gas tank must be removed.



LICENSE PLATE HOLDER FOR BUELL XB9R, XB12R

This bolt-on modification does away with the clunky stock license plate and cleans up the appearance of the back of the bike. Plate holder is a brushed finish stainless steel part with lightening holes. Complete with hardware and instructions

TL-353

BILLET FOOTPEGS FOR S1, S2, S3, M2, AND X1

Replace the stock spongy footpegs with these beautifully machined billet pegs which feature a knurled surface and levelling screws to compensate for wear. They fit both rider and passenger peg mounts. Matching knurled toe pegs are available for the shift and brake levers.



HD083B Footpegs (pair)

HD083B-GP GP Style Footpegs for X1, S1, M2 (pair)



HD084B Toepegs (pair)

BAR END MIRRORS

High quality bar end mirrors eliminate the need for fairing mounted mirrors and provide better rearward vision. Same mirror fits left or right-hand side.

MBE875 7/8" dia. bars only (each)



S1 LICENSE PLATE HOLDER

Relocate the license plate to a more attractive location below the stock rear tail light with this double laminated stainless steel plate holder. The stock license plate light is retained.

IMPORTANT: This kit requires the stock S1 inner fender to be removed or replaced with a S2 fender. **TL-351**

X1 LICENSE PLATE HOLDER

Relocate license plate below the tail light for a cleaner look. Installation requires modification of underseat storage box. Complete instructions and hardware included. **TL-352**

SWINGARM AND FORK SLIDERS

These nicely machined RhinoMoto black ABS sliders help protect your expensive fork and swingarm parts from crash damage on the street or track. Supplied with mounting hardware and installation instructions.

150-0016 Fork Sliders

150-0017 Swingarm Sliders



STORZ/CERIANI STEERING DAMPER KITS

Our racing quality CERIANI steering dampers set the industry standard, offering significant improvements over our previous models. These precision made rebuildable racing dampers feature 16 position positive click adjustment with a new internal valving system that provides a more linear and gradual adjustment of the damping force with stiffer final settings. Smooth and consistent damping combined with a shorter overall length-to-travel ratio is the result from the new Ceriani design.

Damper are sold individually or in kit form. All complete kits permit full movement of the front fork assembly.

Only a few kits are shown here, for a complete listing see page 18.

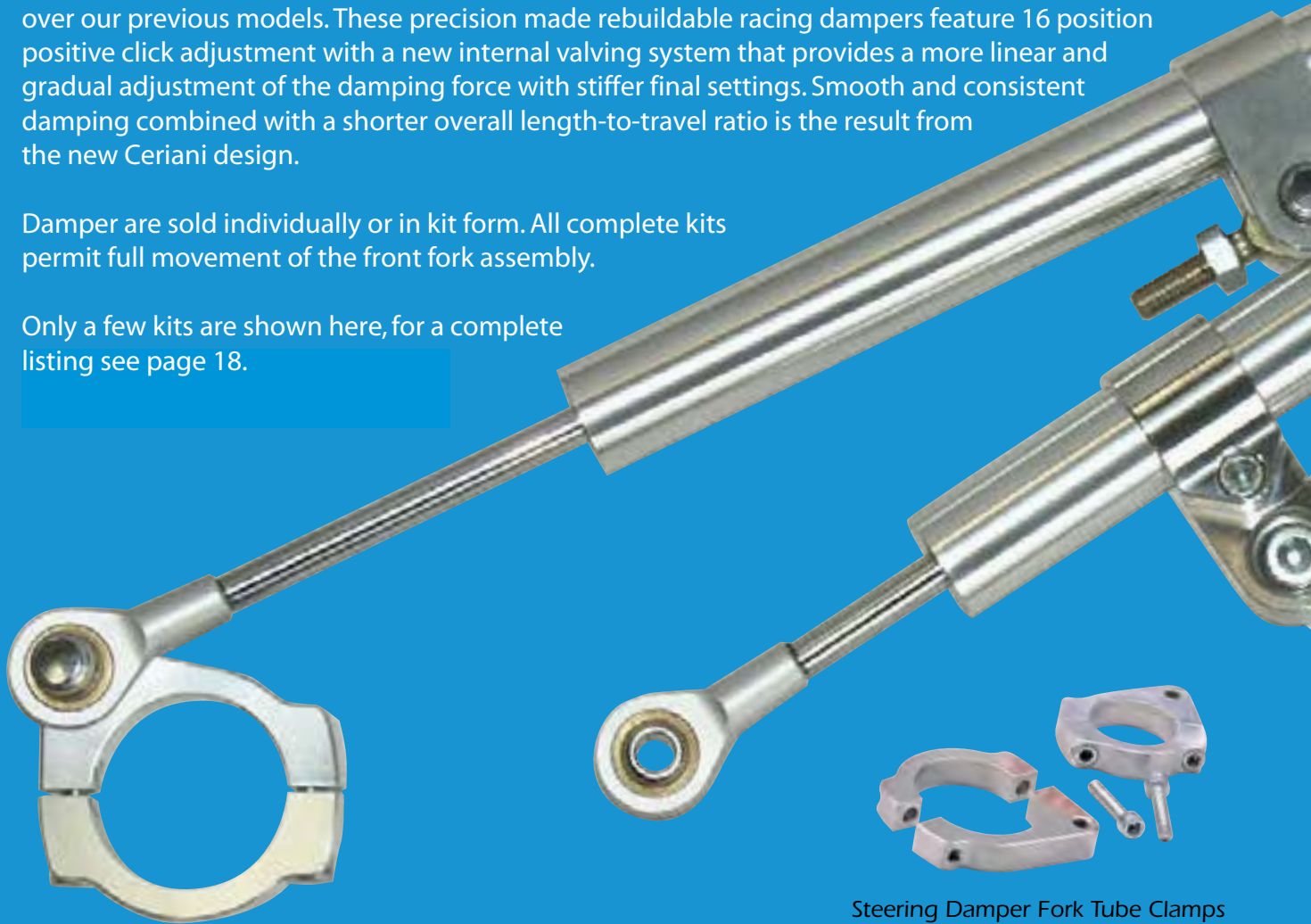

Steering Damper Fork Tube Clamps

For most Buells



Harley Davidson Dyna



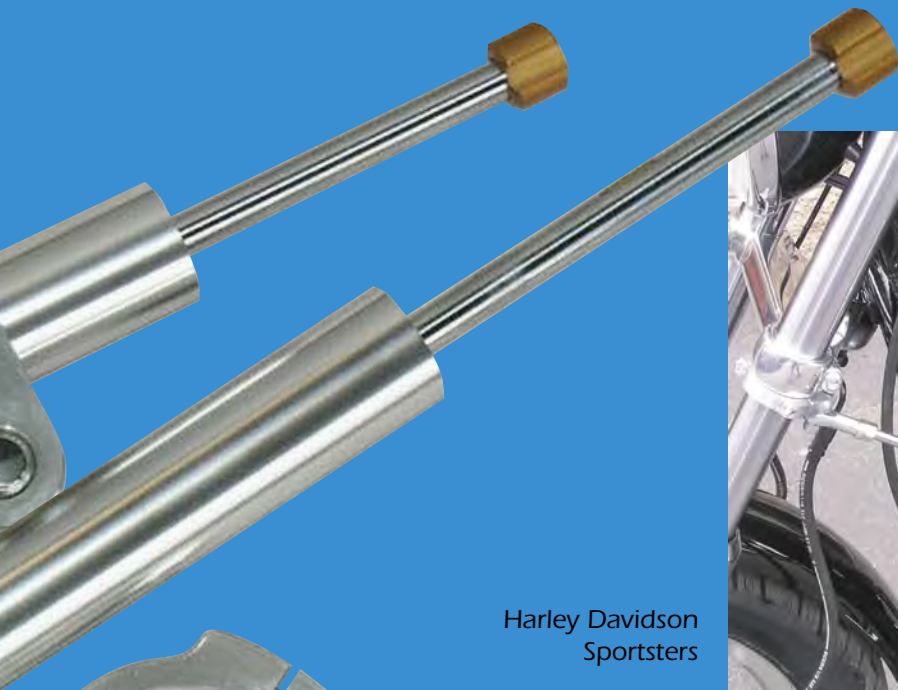

Harley Davidson Sportsters

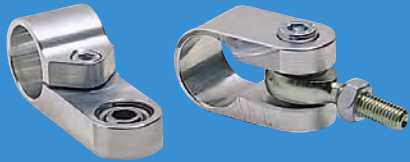
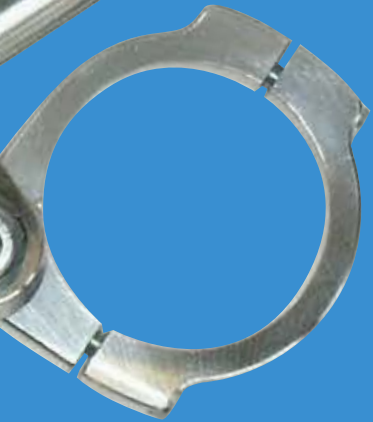

Steering Damper Body Clamps



Ducati Hypermotard



Ducati Sport Classic

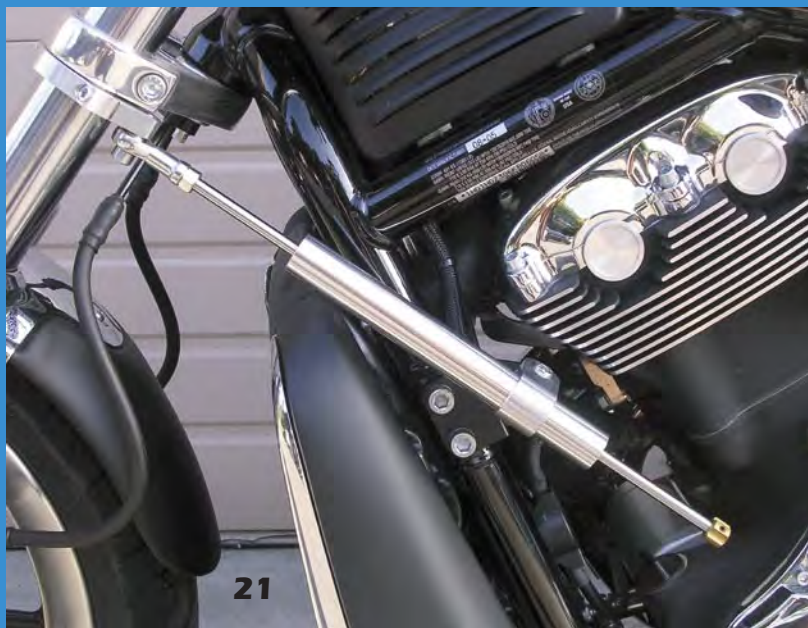

Harley Davidson V-Rod

STEERING DAMPER APPLICATIONS AND SPECIFICATIONS

All kits below are “side mount” style with the damper positioned alongside the frame. Most have the adjustment knob facing towards the front of the motorcycle.

Some kits require drilling (4) 3/16” diameter holes in the frame spar for attachment of an aluminum mounting lug. These kits are identified with a **yellow highlight**.

Kit numbers 22171 and 22208 require drilling a single 25/64” hole in the frame to accept a threaded insert. All kits are supplied with necessary mounting hardware and complete instructions.

COMPLETE STEERING DAMPER KITS Please call for current applications not listed.

22121	Buell M-2 Cyclone 1997-02	HDFXD-39	H-D Dyna 1991-05, 39mm fork
22120	Buell S1/2/3 1995-01	HDFXD-41	H-D Dyna 1991-05, 41mm Wide fork
22122	Buell XB9R, XB12R	HDFXD-49	H-D Dyna 2006-Present
22123	Buell XB9S, XB12S, XB9SX	HDFXD-55	H-D Dyna 1991-05, 55mm Mid fork
22124	Buell XB9R 2005-06	HDFXR-39	H-D FXR all years, 39mm fork
22125	XB9SX/12S/12SS/12SCG 2005-06	HDFXR-55	H-D FXR all years, 55mm Mid fork
22100-SC	Ducati Sport Classic (unfaired)	HDVR-49	H-D V-Rod w/49mm conv. fork
22900	Ducati 900SS/SL/SP 1991-98 (full fairing)	HDVR-56	H-D V-Rod w/Inverted fork, 2009-Present
22900MHR	Ducati Hailwood Replica*	22605	Suzuki GSXR600 1997-02
22901	Ducati 900SS 1999 (full and half fairing)-02	22167	Suzuki GSXR750 1991-93*
22900M	Ducati M900 Monster 1993-02	22166	Suzuki GSXR750 1994-95
22903	Ducati Hypermotard 2008	22164	Suzuki GSXR750 1996-97
22651	Honda CBR900RR 1993-95	22171	Suzuki GSXR750 1997-99
22652	Honda CBR900RR 1996-99	22198	Yamaha YZF600 1995-96
22655	Honda VTR 1000F 1998-02	22205	Yamaha YZF1000 1997
22192	Kawasaki ZX-6RR 2002-03	22208	Yamaha YZF1000RI 1998-02
HD883-D	H-D Evo Sportster 35mm fork	22209	Yamaha YZF600 R6 1999-02
HD883-L	H-D Evo Sportster 39mm fork	22172	Suzuki GSXR750 2000-02*
HD883-R	H-D Sportster 2004-10	22176	Suzuki GSXR1100 1990-92*
HD1200R	H-D XR1200 2010	22196	Yamaha FZR400/600 1989-97

*NOTE: These kits consist of a damper only! They are installed using the **stock mounting hardware** which is already on your bike.

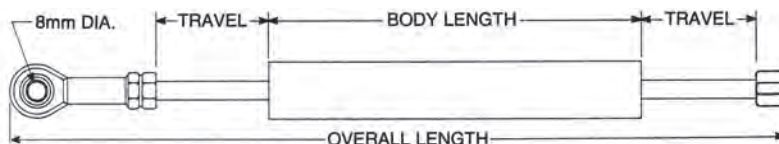

DAMPER ONLY (Dimensions without clamp)

Part Number	Body Length	Overall Length	Overall Travel
SD-68	5 7/32" (133mm)	10 5/8" (271mm)	2 17/32" (65mm)
SD-125	7 11/32" (186.5mm)	14 15/16" (379.4mm)	4 13/16" (122.2mm)
SD-148	8 1/4" (209.6mm)	16 3/4" (425.5mm)	5 3/4" (145mm)
SD-165	8 15/16" (227mm)	18 1/8" (460.4mm)	6 3/8" (162mm)

DAMPER CLAMPS (Sizes to fit forks)

DC350 35mm diameter	DC450 45mm diameter
DC360 36mm diameter	DC480 48mm diameter
DC370 37mm diameter	DC490 49mm diameter
DC380 38mm diameter	DC500 50mm diameter
DC390 39mm diameter	DC510 51mm diameter
DC400 40mm diameter	DC520 52mm diameter
DC410 41mm diameter	DC530 53mm diameter
DC416 41.6 diameter* (fits Marzocchi M1R)	DC540 54mm diameter
DC420 42mm diameter	DC545 54.5mm diameter
DC430 43mm diameter	DC550 55mm diameter
	DC560 56mm diameter

*These are 1-piece fork tube clamps

STORZ SUPERBIKE BAR MOUNTS



Superbike Bar Mount shown with Daytona Touring Bar in chrome (bar also available in black powdercoat finish)

Comfort kits for superbikes

For sportbike owners who are unhappy with the riding position provided by their stock “clip-on” type bars, Storz Performance offers these billet aluminum CNC machined handlebar mounts designed to bolt directly to the stock top triple clamp. Advantages include:

- More comfortable riding position
- Higher bar location places less weight on your wrists and lower back
- Better handling - increased leverage provides a lighter, quicker steering feel that is more responsive to rider input
- Lower replacement cost - conventional tube type handlebars can be replaced at a fraction of the cost of the stock clip-on bars
- More choices - select the bar that fits your riding style - we stock a variety of K&N and Flanders handlebars in chrome and black chrome finishes



Kawasaki Concours



SUPERBIKE BAR MOUNT APPLICATIONS		Bar Mount Color	Recommended Handlebar	Brake Hose Required
SB-025	Kawasaki Ninja 600 1986-87, Ninja 750 1987-90 Ninja 900 1984-86, Ninja 1000 1986-87, Concours 1986-2004, ZX-10 1988-90	Black	G.P. Touring G.P. Touring Daytona Touring	0815 0815 0816*

* For Concours the 0816 hose is only required for 1986-1993 models.

SUPERBIKE BARS						
	Width	Rise	Pull Back	Center Width	Chrome	Black Chrome
Daytona Touring	29.5	3	7	5	650-04601	650-04602
European	29 1/2	2	5 1/2	4 1/2	90-0040	91-0040
GP Touring	28	2 1/2	6 3/4	5	650-04301	650-04302
Superbike	29	2 1/2	5	4 1/2	650-04201	650-04202

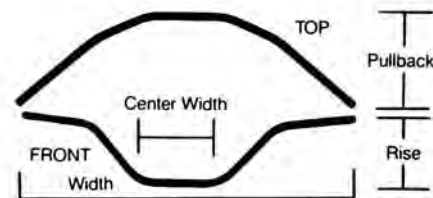

STORZ DIRT TRACK STYLE CONVERSION FOR SPORTSTER 2004 AND UP

The love of dirt track racing runs deep here at Storz Performance, so what better way to celebrate our 25th year than building a new XR style Sportster. Harley introduced the new Sportster in 2004 with a rubber mounted engine. It is easily the best handing Sporty ever produced. So good that we just had to develop an XR style conversion kit for it. The new rubber mounted engine design created a number of obstacles in the development of rear set footpegs, exhaust system mounting, shift mechanisms, and bodywork. But all of these Sportster 1200 dry weight at 557 lbs. The XR1200 that you see here weights in at 474 lbs. dry. That's a whopping 83 lbs. less!



Flanders Café
Handlebar
Dirt Track Style
Alloy Gas Tank



Tail Light and License plate holder



Fiberglass seat with Saddlemen pad

All of the accessories we developed for this bike will fit any of the 2004-Present Sportster models, 883 or 1200.

Modifications include: Hand formed alloy gas tank, fiberglass seat with Saddlemen pad, chrome Storz XR style high pipe exhaust system with wrap around chrome heat shields by BUB, 18" alloy rims with Buchanan stainless spokes, Metzeler tires, Storz rear set footpeg kit, Galfer wave rotors on special Storz floating centers, Flanders Café bars, PM Contour Controls & brake calipers, Dakota Digital tach/speedo, and Storz Ceriani 55mm Inverted forks.



Storz/Ceriani
55mm Inverted Fork

10" Rear Disc Kit



HD883-R Steering Damper
Kit for Rubber Mounts
Sportsters 2004 and up

**COMPLETE
TURN KEY BIKES**

Call for details on a
complete Sportster conversion
(805)641-9540



Rear Set Footpegs Kit



Supertrapp Flat Track Style Exhaust for 2004 to Current Sportsters
Note: Intended for use on closed course competition motorcycles only

Storz SP1200 Dirt Track Style Conversion For Sportsters 2004 AND UP

Frequently Asked Questions

1 Do I Have To Purchase The Complete Conversion Kit?

No, all items in the kit are sold individually so you can build the bike as your budget allows and select only the items you want. The prices for individual parts are available on our website.

2 What Year Model Sportster Will The Storz Conversion Kit Fit?

The kit parts are intended for 2004-2009 model Harley-Davidson Sportsters, 883 or 1200 models. We recommend starting with the 1200R model with optional wire spoke wheels. NOTE: We offer similar dirt track style kits for 1986-2003 model Sportsters also.

3 How Can I Achieve The Storz Dirt Track Look At A Minimal Cost?

The major items that create "the look" are the Storz/BUB exhaust, and our fiberglass seat section with Saddlemen pad which can be used with your stock fuel tank. Other items such as the 18" wheels can be added at a later date.

4 Will The Storz/Bub Exhaust Pipes For The 1986-2003 Model Sportsters?

No, because the 2004 and Up model Sportsters have a rubber mounted engine which necessitates a different design for exhaust mounting.

5 Are The Storz/Bub Exhaust Pipes Available In Different Finishes?

Yes, they are available in chrome or black ceramic coated finishes and both types feature heat shields which cover the head pipe from the cylinder head to the start of the tapered megaphone. All pipes have billet end caps.

6 Will The Storz/Bub Exhaust Pipes Work With The Stock Sportster Footpegs?

They will work with the standard mid mounted footpegs, but not with forward controls.

7 Are The Seat, Fuel Tank, And Fender Available As Painted Parts?

Unless we're building a complete turnkey bike for you, we don't offer them painted. The seat section is supplied in white gelcoat finish, the alloy gas tank is in bare aluminum, and the front fender in black plastic finish.

8 Are Alloy Gas Tanks And Exhausts Available For Fuel Injected Sportsters?

Yes they are. Exhaust systems have a provision for the stock oxygen sensors and the fuel tanks will accept the stock Sportster fuel pump.

9 Do The Rear Set Footpegs Have A Standard Shift Pattern?

Yes, the shift pattern is a standard down for first gear, up for higher gear patterns.



Complete Storz Conversion based on 2007 Sportster 1200R model equipped with standard fuel injection.

STANDARD OPTION GROUP "A" (using stock H-D controls, tach & speedo)

PART NO	DESCRIPTION
AT-1200	Alloy Fuel Tank (unpainted for 2004-2006 Sportster)
AT-1207	Alloy Fuel Tank (unpainted for 2007+ Sportster except H-D XR1200)
PG3211	Pingel Petcock for AT-1200
FGL-250	Fiberglass Seat & Pad (for use with alloy fuel tanks)
FGL-255	Fiberglass Seat & Pad (for use with stock R model tank)
IF-250	Inner Fender for 2004-2006 Sportster
IF-255	Inner Fender for 2007+ Sportster
ML-051-04	Seat Mounting Kit with Tail Light for 2004+ Sportsters
KSB-88312	Storz/BUB Exhaust, chrome finish, 2004+ }
KSB-88312-B	Storz/BUB Exhaust, black finish, 2004+ }
HD083-04	Rear Set Footpeg Kit 2004+
HD255B.3132-SSB	Front Fork Legs, Satin Black
HD255.03SC	Mid Glide Triple Trees, Satin Clear
HD4335	Billet Handlebar Mounts
HLB4354	Headlight Bracket for stock visor mount headlamp
650-08575	Flanders Café Handlebar
08836	Front Brake Line Kit
08845	Rear Brake Line Kit
SR1200WT	Chain Drive Kit for 180/55-18 tire
RD1200	10" Rear Wave Disc Kit without caliper
RD1200G	10" Rear Wave Disc Kit with Grimeca 1050/55 caliper
FD1200	13" Front Wave Disc Kit
BRS350	Front Polished Rim & Spokes Kit, 18 x 3.5"
BRS550	Rear Polished Rim & Spokes Kit, 18 x 5.5"
ME880F	Metzeler Front Tire (130/70-18)
ME880R	Metzeler Rear Tire (180/55-18)
BR-LACE	Lace & True Wheel Assembly
M1662.02	Front Fender, unpainted
HD45A.65B	Front Fender Bracket Kit
0051-2913B	PM Front Brake Caliper 6 Piston, Black
0052-2400B	PM Rear Brake Caliper 4 Piston, Black

NOTE: Intended for use on closed course Competition Motorcycles only.

OPTION GROUP "B" (Performance Machine Billet Hand Controls & Dakota Digital Tach/Speedo)

PART NO	DESCRIPTION
0063-2002B	Throttle Housing, Black
0062-2032	Switch Assembly, Right hand
006202035	Switch Assembly, Left hand
0062-2510B	Brake Light Switch, Front
0062-2030B	Clutch Lever Assembly, Black

STORZ DIRT TRACK STYLE CONVERSION - 1986 to 2003

Starting with any 883 or 1200 model Evolution Sportster (1986 - 2003) you can achieve the Dirt Track racer look shown here. Most of the components feature simple bolt-on installation and most items are also suitable for the 1983-84 XR1000.

The rear-set footpegs and dirt track seat give you a more aggressive riding stance and the beautifully hand formed aluminum alloy fuel tank offers a 2.75 gallon capacity. The 10" rear disc kit features a floating style bracket that transfers braking torque directly to the frame instead of the swingarm to decrease wheel hop under heavy braking. The front fender is a stock Sportster item.

Our Storz / Ceriani Black Satin 55mm Inverted Fork handles the suspension chores up front and Works Performance billet aluminum shocks suspend the rear.

All kit pieces are offered individually so you can build the bike as your budget allows.

"The Storz Performance XR883 blends the rugged styling of an XR750 dirt-track racer with the reliability of a stock Sportster.... a nimble-handling, good-running, sweet-sounding honey of a motorcycle that just happens to look like it got lost on the way to the San Jose Mile."
Cycle World

**Start with a
Sportster...**



Wind up with this!



Dirt Track Style Seat with Saddlemen Pad



Underseat tail light
1994 to 2003



10" Rear Disc
Brake Kit



Storz / Ceriani
Forks

Braided Steel
Brake Lines



Storz / Ceriani
Steering Damper Kits



Dirt Track Style
Alloy Gas Tank

Sun 18" Alloy Rims and Stainless Spokes



Rear Set Foot Pegs



DIRT TRACK STYLE FIBERGLASS SEAT CONVERSIONS



FGL-250

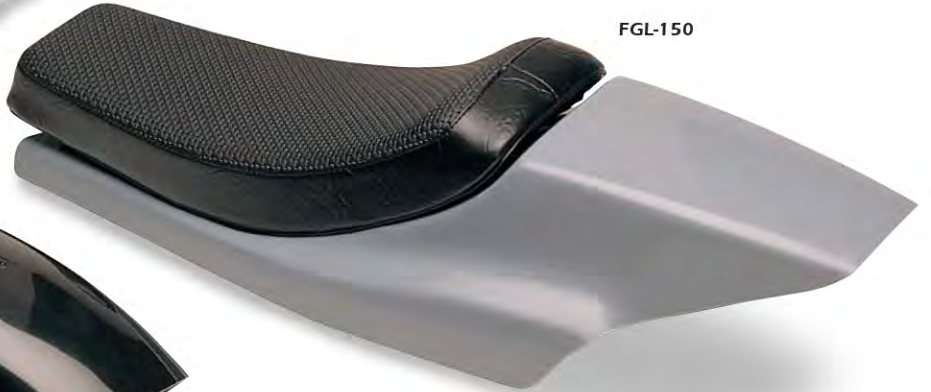

FGL-150



IF-150



2004-Present



1994-2003



1982-1993

Our hand laid fiberglass seats are supplied in gelcoat finish and include a special Saddlemen seat pads. Seat mounting kits and inner fender must be ordered separately. 1994-2009 Sportsters have underseat mounting of the license plate and tail light.

FIBERGLASS SEATS WITH PAD

- FGL-150** Dirt Track Style 1986-2003
- IF-150** Inner fender for 1986-2003
- FGL-250** XR Style for Sportster 2004-Present (Alloy tank)
- FGL-255** XR Style for Sportster 2004-Present (Stock tank)
- IF-250** Inner fender for 2004-2006
- IF-255** Inner fender for 2007-Present

SEAT MOUNTING KITS

- ML-051** Seat mounting kit for 1982-93 Sportster & XR1000
- ML-051-94** Seat mounting subframe kit for 1994-2003* (includes tail light and stainless steel license plate holder)
- ML-051-04** Seat mounting subframe kit for 2004-2010 (includes tail light and stainless steel license plate holder)

***NOTE:** For 1994 and later Sportsters seat kits we recommend that the stock fender support rails be shortened. A template is included with instructions.



2004-Present (with stock gas tank)

ALLOY GAS TANKS

ROAD RACE STYLE

This beautifully made hand-formed aluminum road race style tank features an internal baffle, flush mount aircraft style filler cap, and 3.5 gallon capacity. It is supplied with mounting hardware and brackets.

- AT-883RR** Road Race Style, 883/1200, 1986-2003
(use with FGL-200 seat & pad, see page 38)
- AT-1200RR** Road Race Style (see page 3) 2004-06
- AT-1207RR** Road Race Style (see page 3) 2007-Present

DIRT TRACK STYLE

These beautifully hand formed tanks are used on our 883 and 1200 Sportster based dirt track style conversion kits. Flush mount aircraft style gas caps are standard. 1983-2003 tanks (not shown) use a center mount system, 2004-Present tanks have a smooth top and use concealed bolt-on mounts.

- AT-883** Alloy Tank Dirt Track Style for 883/1100/1200, 1986-2003
- AT-1000** Alloy Tank Dirt Track Style for XR1000, 1983-1984
- AT-1200** Alloy Tank Dirt Track Style for 883/1200, 2004-2006 (not shown)
- AT-1207** Alloy Dirt Track Style 883/1200, 2007-Present
- AT-750** Alloy Dirt Track racing tank for XR750 (not shown)

ALLOYTANKINSTALLATIONNOTES: Alloy tanks have a 3/8 NPT thread and will accept Pingel Petcocks. Horn must be relocated from stock mounting position. 1994-2003 model Sportsters require ignition switch to be relocated.

PINGEL PETCOCKS

These beautifully machined petcocks have the largest fuel flow on the market with the smallest compact size. They feature On-Off-Reserve positions (except racing petcocks, on-off only) with an easy twist lever. A special adaptor nut (p/n PG2001) is available for use with stock H-D tanks. Petcocks have a 3/8 NPT thread with 5/16" dia. outlet.

These drawings show the petcocks as you would view them from the top, sitting on the motorcycle.

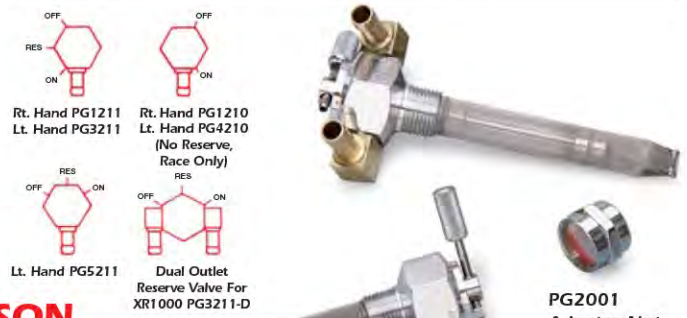

HANDLEBARS FOR HARLEY-DAVIDSON

Flanders Superbar 650-08555
(as used on our 883) - 1" diameter, chrome only Width 29" Rise 2" Pullback 5"



Flanders Drag Bar 650-08575 - 1" diameter flat bar.
Width 28.625" Pullback 5.5"

Flanders Café Bar 650-08575 (as used on our 1200) - 1" diameter chrome only Width 32.25" Rise 2.75" Pullback 7". (not shown)

Solid Bar Mounts SBM01 - Solid steel spacers replace the standard H-D rubber mounts for rigid handlebar mounting.



STORZ REAR SET FOOTPEGS FOR SPORTSTERS



Rear Set Kits for 2004 - 2013 (non-ABS) Rubber Mount Sportsters (Except H-D XR1200)



2004-Present left side,
std. shift pattern for
high or low pipe.

2004-Present
right side brake



1994-2003 left side,
std. shift pattern

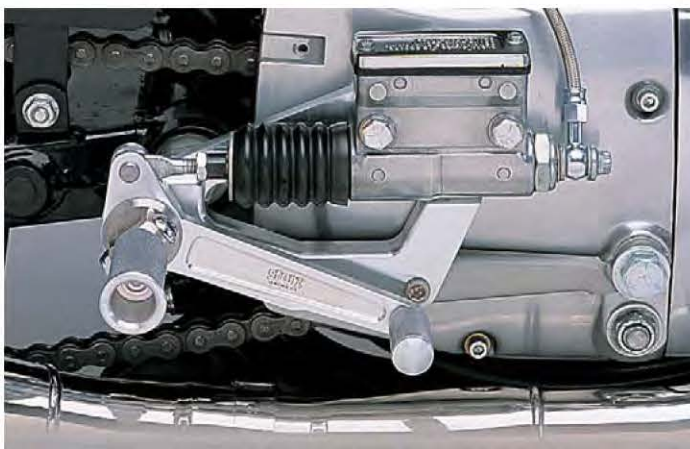

1991-2003 right side brake
(low pipe)

Our beautifully machined billet aluminium rear set footpeg kits are available for 1986-Present model 883, 1100, & 1200 Sportsters. These bolt-on kits relocate the footpegs to a more sporting rearward position which is comfortable without being too aggressive. The footpegs, levers, and mounting brackets are CNC machined from solid 6061-T6 aluminium. They are designed to bolt directly to existing holes in the stock primary cover, sprocket cover, or frame.

Our knurled aluminium footpegs feature leveling screws to compensate for wear and our footpeg pivots will also accept the standard H-D rubber covered passenger pegs. Complete instructions and hardware are included and no drilling is necessary for installation.

NOTE: Storz rear set footpeg kits are not compatible with the stock Sportster exhaust system. They require the use of an aftermarket exhaust such as a 2:1 low pipe or 2:2 high pipe which does not run across the sprocket cover.

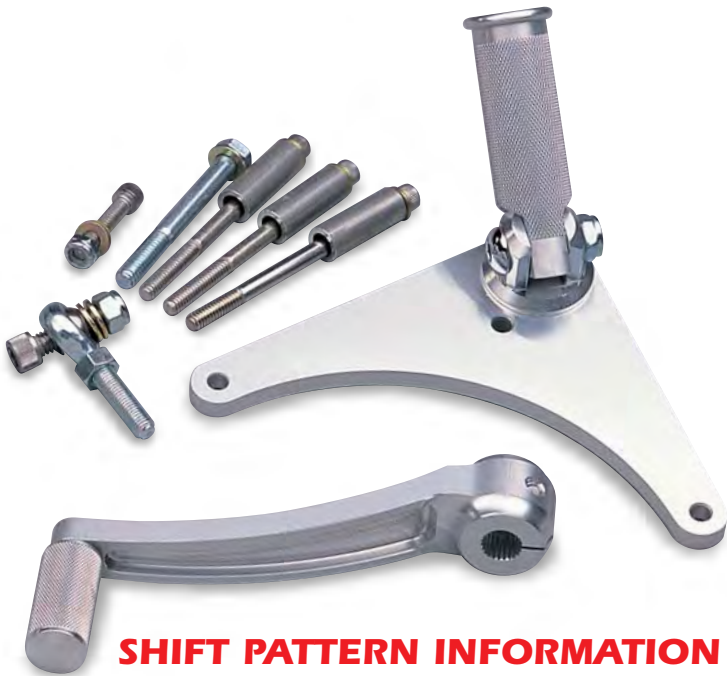

Left Side, 4 or 5 Speed, Reverse shift pattern 1986-2003



SHIFT PATTERN INFORMATION

4 speed kits (1986-90 models) use a reverse shift pattern, up for first gear, down for higher gears. 5 speed kits (1994-2003) are available with a reverse pattern or standard pattern, down for low gear, up for higher gears. 2004-2009 kits are available in standard shift pattern.

STANDARD SHIFT PATTERN

HD083-91LKS	5 speed using high pipe, 1994-2003
HD083-91S	5 speed using 2 into 1 low pipe 1994-2003
HD083-04	5 speed using high BUB/Storz pipe, 2004-2010
HD083-1200R	5 speed using high BUB/Storz high pipe for H-D XR1200, 2008-2010



REVERSE SHIFT PATTERN (recommended for racing use only)

HD083	4 speed using low pipe 1986-1990
HD083-LK	4 speed using high pipe 1986-1990
HD083-91	5 speed using low pipe 1991-1993
HD083-91LK	5 speed using high pipe 1991-1993
HD083-94	5 speed using low pipe 1994-2003
HD083-94LK	5 speed using high pipe 1994-2003



Ordering Information You must specify:

- 1) Model year
- 2) Type of Exhaust
- 3) Desired shift pattern, reverse or standard

***IMPORTANT:** Storz rear set footpeg kits are not compatible with the stock exhaust system. They require the use of an aftermarket exhaust which does not run across the sprocket cover.

REPLACEMENT PARTS

Shift Lever with Knob

HD083.01	Reverse pattern, 4 spd., 1986-90
HD083.02	Reverse pattern, 5 spd., 1991-93
HD083.20	Reverse pattern, 5 spd., 1994-03

Knurled Replacement Footpeg (fits late model H-D) **HD083.03**

REAR BRAKE LINE KITS

Braided steel hose kit with t-fitting for brake light switch

08835	For rear set kits using low exhaust pipe 1986-2003
08840	For rear set kits using high exhaust pipe 1986-2003
08845	For rear set kits with stock brake, high pipes 2004-2010
08850	For rear set kits with Storz 10 in disc kit, high pipes 2004-2010
08860	For rear set kits with stock brake, high pipes for H-D XR1200 2004-2010
08855	For rear set kits with Storz 10 in disc kit, high pipes for H-D XR1200 2004-2010

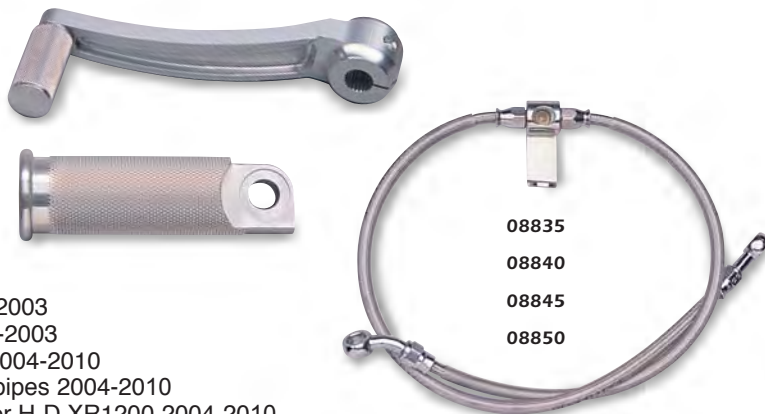

GRIMECA DISC BRAKES

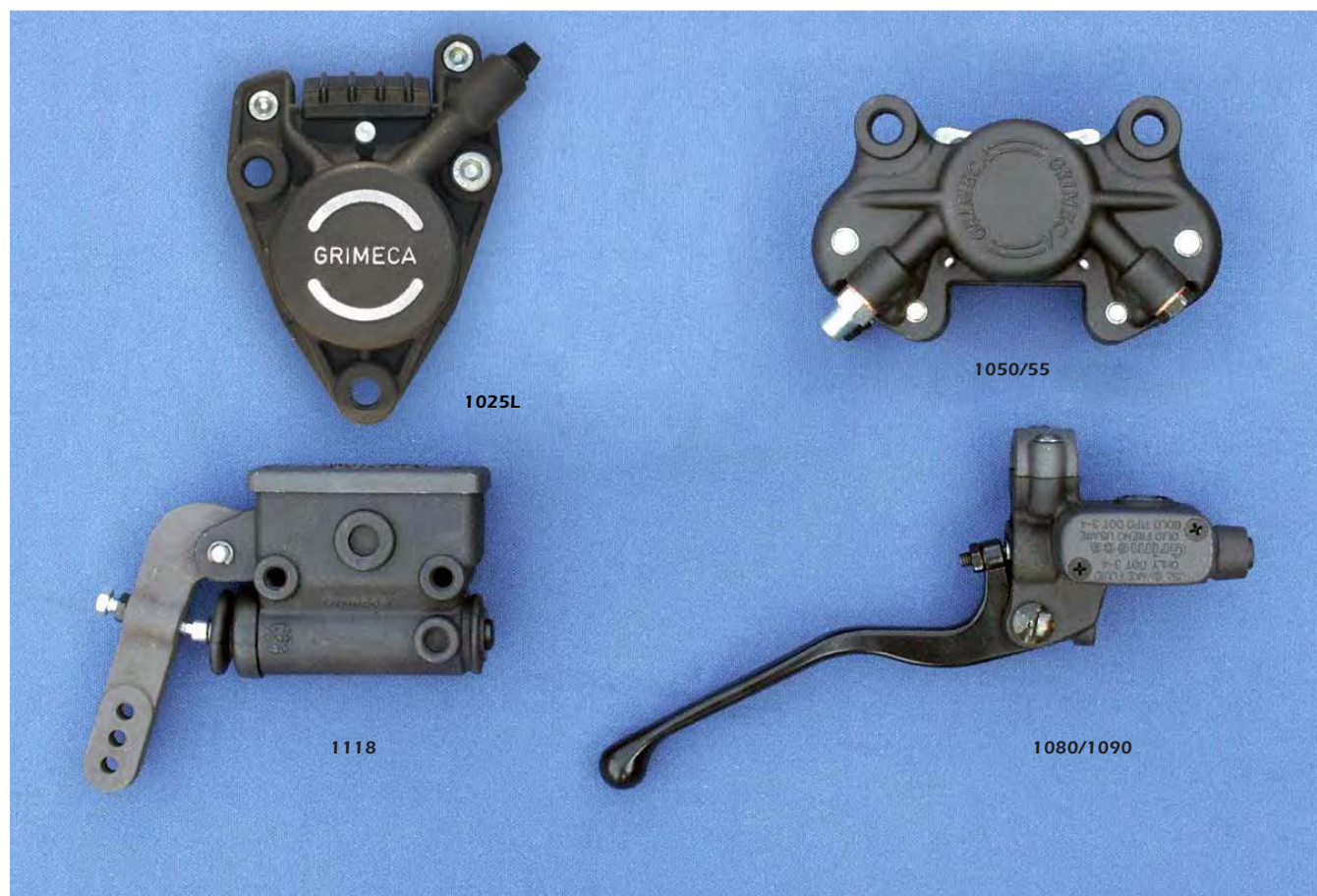

Storz Performance is a direct importer of these well-made Italian disc brake components for dirt track, road race, and drag race applications. These components are precision die cast aluminum with hard anodized alloy pistons. All calipers are dual acting and feature Ferodo brake pads that quickly detach without wheel removal. Grimeca brake calipers and master cylinders are threaded to accept 8mm x 1.0 fittings for attachment of brake lines.

Contact us for proper matching of master cylinders and calipers. We have the best service, price and inventory of Grimeca components.

1025L A powerful compact brake caliper with dual 41mm pistons. Smaller in overall size than the 1050/55, it is often used in dirt track or custom applications. Weight is 1lb.15oz.

1050/55 One of the most versatile and popular calipers in the line is the 41mm piston "Lockheed style" caliper. Recently updated, it now features two extra bolts through

the lower part of the caliper body for added rigidity. It is also machined to accept bleed screws and inlet fittings on either side so that it can be used for left or right-hand applications. Mounting holes are 3.5" on center and the weight is only 2 lbs. 9 oz.

Rear Master Cylinder 1118 - Rear masters are available only in the 19mm size with lever in down position. An optional "up lever" is also available (p/n GR1260). Total weight is only 14 oz.

Handlebar Master Cylinders - Models 1080 (13mm piston dia.) and 1090 (14mm dia.) are lightweight, compact master cylinders with rectangular reservoirs for use with 7/8" diameter handlebars only. They can be used with "banjo" or screw-in fittings.

Note: Rebuilding kits available for all calipers and master cylinders. Caliper kits include new pistons and "O" rings, Master Cylinder kits include new pistons, "O" rings, and return springs. Order brake pads separately.

GRIMECA BRAKE PADS

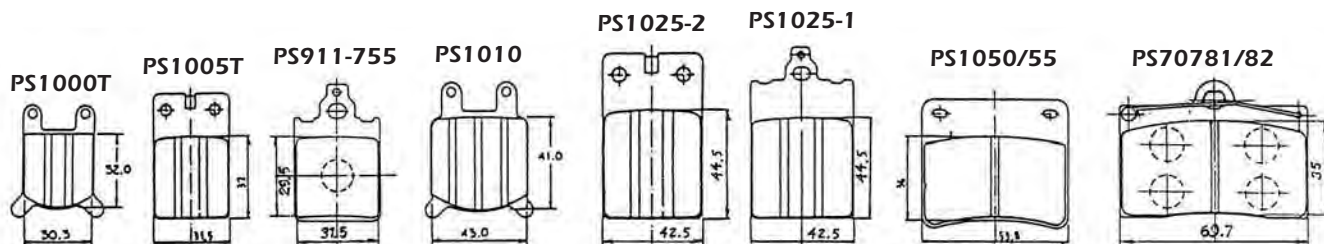

THROTTLES, GRIPS AND LEVERS

Quick turn nylon throttles are available in dual cable (XR750), single cable and "push-pull" configurations for 7/8" bars. Oury grips in black only. Magura power levers with two-piece clamp for quick change.

60714 Dual Cable Throttle **60712** Push-Pull Throttle
60715 Single Cable Throttle

Kill Button - High Quality kill button for 7/8" bars. **03063**

Quick Turn Throttle - A large diameter drum gives this throttle an extremely short throw for "instant-on" throttle response. Quick change cover plate allows the cable to be changed without removing the throttle from the handlebars. For 7/8" bars. **MG226**

67211 Magura Power Lever-Clutch

Part numbers **60714** & **60715** are for **RACING USE ONLY**. These throttles are only for use with slide type carburetors which do not have a provision for "push-pull" cable operation.



DIRT TRACK FOOTPEGS

Universal "Bates" style footpegs for dirt track or custom application with Bates logo on rubber.

FPG491R Footpeg Rubber-each
FPG490 Footpeg Assembly-each



FPG491R



FPG490



DIRT TRACK AIR CLEANERS

RU-1240 7" - STD. XR with Mikuni
RU-1260 9" - LONG XR with Mikuni

RU-1360 6" - Oval - Mikuni
RU-1540 6" - Dellorto 500 Honda, 500 Yamaha

RU-1830 7" - New style for XR750, RS750

62-1250 3" - Crankcase vent filter for XR750

RU-1370 5" - Stock XR1000 replacement

62-1000 2" - Crankcase vent filter for Sportster



FLANDERS DIRT TRACK HANDLEBARS

	Width	Rise	Pull Back	Center Width
650-01201#7	32-1/2"	4-1/2"	10-1/2"	5"
650-01211#10	34-1/4"	4-1/2"	8- 3/4"	5"
650-01221#24	34-1/2"	3-1/2"	9"	5"

Dirt track handlebars are in chrome only.

HS875 Set of 4 handlebar shims

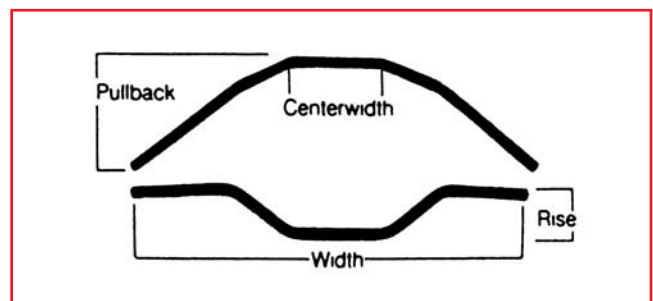



STORZ REAR BRAKE DISCS For dirt track and custom applications

Storz discs are primarily for dirt track use. The 10" diameter ductile iron discs feature high heat capacity and warp resistant qualities. They are .200" thick and are grooved on the disc surface to vent the boundary layer of gases that build up between the pads and disc under hard braking. The ductile iron construction provides a high coefficient of friction. The 10" disc is for rear wheel application only and is available with a lightweight aluminum center section to fit Barnes type quick change wheels.

SDQC10

GRIMECA BRAKE CALIPER MOUNTING BRACKET

For use with our 10" quick change rear disc only, we offer an aluminum mounting bracket designed to accept the Grimeca 1050/1055 caliper or Lockheed 2-piston caliper. Also shown is our 4130 chrome moly torque arm with Heim joints for anchoring brake bracket.

1050-10RL Left Caliper Mounting Bracket
1050-10RR Right Caliper Mounting Bracket
TA3838 Torque Arm



REPLACEMENT FORK PARTS AND OIL SEALS

FORK TUBE TOP CAP PLUGS

CE3524 Top cap plug for Old Style 35mm fork
DT38A.03 Top cap plug w/air fitting for DT38A fork
DT42A.03 Top cap plug w/air fitting for DT42A fork
HD54A.23 Top cap plug w/air fitting for HD54 Series Inverted fork

OIL SEALS

CE3507 Old Style 35mm Road Race fork (requires 2 per leg)
04006L HD54D Forcelle Italia Inverted fork, 40mm steel tube
04306 HD54A, HD54WG, HD43A, HD43WG, DT43A, for G.C.B. Conventional and Inverted forks with 43mm steel tube
HD55.22 45mm fork seals fits all HD45 and 55 series forks
HD49.22 49mm fork seals for HD49 series forks

DUST BOOTS

CE3510-R Good quality reproduction of original dust boots for style 35mm Road Race forks.





Steve Morehead, Dirt Track Legend



WARNING: DO NOT modify or machine axle in any way! For front wheel mounting information contact: STORZ Performance, Inc.

AXLES AND WHEEL SPACERS

Front Axles

- 05053** 55mm wide glide axle
- 05051** 55mm mid glide axle

HEIM JOINTS

Spherical rod ends for brake anchor rods. Aircraft quality 3/8" hole in ball end. 1/4" x 1/4" size also available for brake pedal linkage.

- HM006** Heim Joint Male 3/8" x 3/8"
- HM004** Heim Joint Female 1/4" x 1/4"



NUMBERS AND PLATES

Vinyl Stick-on Numbers (Black or White, 3 per pack)

- | | | |
|-----------------|-----------------|-----------------|
| 52081 #1 | 52085 #5 | 52088 #8 |
| 52082 #2 | 52086 #6 | 52089 #9 |
| 52083 #3 | 52087 #7 | 52080 #0 |
| 52084 #4 | | |

- 50989** Flexible Plastic Number Plate
- 52227** Stick-on Background Kit (specify color - black, white, yellow)

FGL-045 Plastic Number Panels (side panels)



GREEN STRIPE HOSE

Carburetor mounting hose for spigot mount carbs.

1-1/2" size fits
36/38mm Mikuni
spigot mount carbs.
Supplied in 1' lengths

- 24224** Green Stripe Hose (per foot) 1-1/2 i.d.
- 24226** Green Stripe Hose (per foot) 1-5/8 i.d.



ALUMINUM QUICK CHANGE HUBS

For racing and custom applications we offer these billet aluminum machined 40 hole hubs. For rear wheel use, the hub may be used with bolt-on adaptors for sprocket and brake disc with quick change "knock-off" nuts. For front use, a brake disc can be bolted directly to the hub flange.

- BH101** Hub Only
- BK0125** Knock Off Adaptor
- BK0002** Knock Off Wingnut
- BK0005** Knock Off Wrench





FIBERGLASS SEATS

These top quality fiberglass seats for dirt track and custom applications are replicas in the style of the original part. All of these seats are supplied with seat pads.

- FGL-020** Fiberglass Seat for XR750 with smooth top pad (not shown)
- FGL-022** Fiberglass Seat for XR750 (spoiler style) with smooth top pad
- FGL-031** Fiberglass Seat Knight with smooth top pad
- FGL-100** Fiberglass Seat XLCR Café racer with smooth top pad
- FGL-150** Fiberglass Seat Dirt Track Style with Saddlemen pad for 1986-03 Sportster
- FGL-200** Fiberglass Seat Road Race Style for Sportster, 1986-03
- FGL-250** Fiberglass Seat XR Style with Saddlemen pad for 2004-08 Sportster (alloy tank)
- FGL-255** Sportster 2004-10 (stock tank)

Sportster Seat Mounting Kits

- ML-051** Seat Mounting Lug only 1986-93
- ML-051-94** Seat Mounting Subframe 1994-03 (includes tail light & license plate holder)
- ML-051-04** Seat Mounting Subframe 2004-10 (includes tail light & license plate holder)



STORZ HAND GUARDS

Universal application handguards attach to bars with hose clamp. Flexible plastic available in red, white, blue.

- HG-150-R** Hand Guard, Red
- HG-150-B** Hand Guard, Blue
- HG-150-W** Hand Guard, White

STORZ FORK PROTECTORS

Durable plastic fork guards available in red, black, white and blue to fit the following forks: Ceriani 35mm, 38mm, 42mm, 43mm. Marzocchi 35mm

- FP-110-R** Fork Protectors, Red
- FP-110-B** Fork Protectors, Blue
- FP-110-W** Fork Protectors, White
- FP-110-N** Fork Protectors, Black



CHEMICAL

Bel-Ray Fork Oil

Recommended for 35mm and 42mm CERIANI damper rod style forks including Dirt Track and Road forks in 15 or 20W. One Liter bottle. **BR15W BR20W**

Bel-Ray HVI Racing Suspension Fluid

Formulated for racing applications, available in 10 or 15W. One Liter bottle (1.056 quarts) **BR-HVI-10W BR-HVI-15W**

Golden Spectro Cartridge Fork Fluid

Recommended for 43mm and 45mm CERIANI forks in H-D applications, both Inverted and Conventional types. Designed to provide "zero stiction". 1 Liter bottle (1.056 quarts) **GS85/150**

K&N Filter Oil

For use on K&N pleated air filters, 6.5 oz. aerosol can. **99504**

Castrol GT LMA Brake Fluid

Exceeds DOT 3 and DOT 4 specifications. OK to use in Grimeca brake components. 12 oz. bottle. **GT304**



ALLOY FUEL FILTERS

Two-piece alloy fuel filters with removable gauze type filter element are available in polished finish for 5/16" fuel lines. Diameter 1.125" Length .950" (body only)

- FF101P** Polished Fuel Filter
- FF101.01** Filter Element
- FF101.02** O Ring, Fuel Filter



T & B TY-RAPS AND SAFETY WIRE

The original black nylon "Ty-Raps" with metaltongue. Stainless aircraft lockwire. .032" in 1 lb. container.

- TB523** T & B Ty-Raps Short 3-1/2" x 3/32" - 100 Quantity
- TB525** T & B Ty-Raps Long 7" x 3/16" - 100 Quantity
- SW032** Safety Wire .032

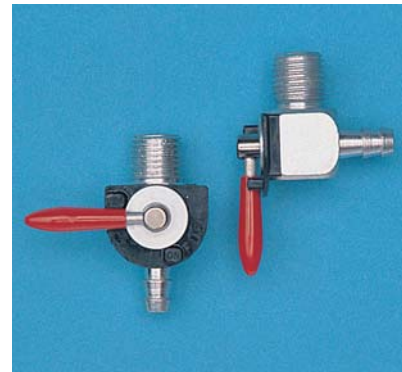

PETCOCKS

For 5/16" I.D. fuel line, cad plated steel petcocks available in 90° or straight outlets and have a 1/4 N.P.T. Thread.

- 53030** Petcock 90 degree Outlet
- 53035** Petcock Straight Outlet

QUICK DISCONNECT FUEL LINE FITTINGS

Lightweight, strong nylon construction in-line fuel coupling for 5/16" i.d. fuel line. Disconnect the two halves and fuel flow is automatically shut off. **QDC170-05**

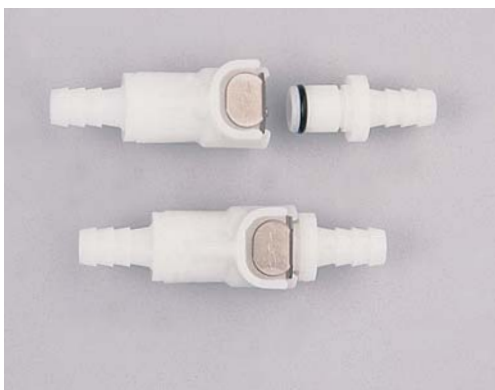

MOTORCYCLE TY-DOWNS

Ankra ty-downs are made of 4000 lb. nylon webbing with mil-spec stitching. 3/8" diameter steel hooks are vinyl coated. Ankra hook extensions are perfect for tying down bikes with clip-on bars. Ankra quick release floor hooks can be removed leaving only the mounting plate on your truck's floor.

- MT01311** Motorcycle Ty-Down(pair)
- MT01320** Ty-Down Hook Extension
- MT01319** Ty-Down Quick Release Hooks



Index

Storz Letter of Introduction	2
Storz SP1200RR Café Racer	3-6
Storz Upgrades for the Harley-Davidson XR 1200	7-9
Wheels Rims and Spokes	10
Brake Kits and Adaptors	11
STORZ / CERIANI FORKS FOR HARLEY-DAVIDSON	
55mm Chrome Inverted Forks	12
55mm "Blackout" Inverted Forks	13
Fork Trees for Inverted Forks	14
Accessories for Inverted and Conventional Forks	15
Braded Steel Hose and Fittings	16-17
SPORT PARTS FOR BUELL MOTORCYCLES	18-19
STEERING DAMPERS AND APPLICATIONS	20-22
Superbike Handlebar Mounts	23
SPORT PARTS FOR HARLEY-DAVIDSON	
Storz Dirt Track Style Conversion for 04 and up Sportsters	24-27
Storz Dirt Track Style Conversion for 86-03 Sportsters	28-29
Conversion Fiberglass Seats	30
Alloy Gas Tanks	31
Pingle Petcocks	31
Handlebars	31
Rearset Footpegs	32-33
Grimeca Disc Brake Components	34
DIRT TRACK COMPONENTS	
Throttles, Grips and Levers	35
Dirt Track Foot Pegs	35
Handlebars and K&N Air Cleaners	35
Storz Rear Brake Disc	36
Grimeca Brake Caliper Mounting Bracket	36
Replacement Fork Parts and Seals	36
Axles and Wheel Spacers	37
Numbers and Plates	37
Heim Joints, Green Stripe Hose	37
Aluminum Quick Change Hubs	37
Fiberglass and Plastic Parts	38
Chemicals and Miscellaneous	39
Index, Ordering Information, Terms and Conditions	40

Business Hours: We're open Monday through Friday from 7:30 a.m. to 4:00 p.m. Pacific Time and we will be happy to answer your questions regarding our products and services during those hours. We are closed on Saturdays, Sundays and Holidays.

Ordering: Call or FAX us listing the part number and description of the parts you require. Include information on size, model, and year of the motorcycle for which the parts are intended. A special order form is available for front fork applications. **Secure online ordering is also available on our website, www.storzperf.com**

Foreign Orders: We ship worldwide daily and we welcome orders from outside the United States. Payment must be made in advance by credit card (VISA or MASTERCARD) or wire transfer. **IMPORTANT:** If you pay by credit card you must include the following:

- 1) Cardholder's name as it appears on the credit card.
- 2) The card number and expiration date.
- 3) The billing address of the cardholder.
- 4) Cardholder's signature

On your request we will be happy to issue a proforma invoice. Please specify UPS shipment or indicate freight forwarder of your choice. We do not recommend postal shipment. All freight charges must be prepaid. **WE DO NOT SHIP FREIGHT COLLECT.**



Terms and Conditions

Terms: All orders will be shipped C.O.D. (usually U.P.S.) including freight and 7 1/4% sales tax for California residents. All items prepaid will be shipped C.O.D. for freight unless freight is also prepaid. Orders prepaid with personal checks, allow three weeks for check clearance. **All prices are subject to change without notice.**

All retail C.O.D. sales will be shipped cashier's check or money order only. We're sorry for this inconvenience but bad checks have necessitated this policy.

Back Orders: All back orders will be held for 30 days. Please cancel by phone or letter any back orders you do not wish held. Title of all merchandise shipped passes to customer upon our delivery to a common carrier. All claims for damage or loss are to be made by the customer

to the freight carrier.

Warranty: Storz Performance will not be held responsible for incidental or consequential damages arising from or in connection with the use of any products sold by Storz Performance. Our guarantee is limited to replacement or repair of defective parts up to 60 days from date of purchase. This warranty does not cover damage caused by misuse, alteration or negligence. All merchandise distributed by Storz Performance is guaranteed in accordance with Manufacturers' own terms of warranty. This warranty is expressly in lieu of any other expressed or implied warranties including any implied warranty of merchantability or fitness for a particular purpose.

Returns: All claims must be made within 30 days of shipping date and must have verbal or written authorization from Storz Performance. A 20% handling charge will be charged unless the return is a result of defective merchandise or an error on our part. No packages will be accepted for return if shipped C.O.D.

Disclaimer: The words Buell, Harley, Harley-Davidson, H-D, Sportster, Wide Glide, Softail, Dyna Glide, Evolution, Springer, and Fat Boy are registered trademarks of the Harley-Davidson Motor Company, Inc. and are utilized in this catalog for reference purposes only. Storz Performance, Inc. is in no way associated with or authorized by Harley-Davidson Motor Co. to manufacture and sell any of the parts in this catalog.

Contents of this catalog are copyright 2011 by Storz Performance, Inc. All rights reserved, including the right to reproduce this catalog or portions thereof in any shape or form. Reproduction of any contents is strictly forbidden without prior written permission from Storz Performance, Inc. All specifications and descriptions of products herein are subject to change without prior notice.

Catalog Design: John Dillingham; Catalog Production: Hugo Viveros
Photography: Kim Photographic

Special thanks to: Cal Coast Motorsports, Ventura, CA;
Ventura Harley-Davidson, Fresno Harley-Davidson.

storz[®]

Performance Inc.



Secure Online Shopping At
www.storzperf.com



239 S. Olive Street Ventura, CA 93001 Phone: (805) 641-9540 • Fax: (805) 641-3650
Business Hours: Monday thru Friday, 7:30a.m. to 4:00p.m. Pacific Time